

# MIDSCI™

Laboratory Equipment & Supplies



HYC-1031GD (115V)



Eco-friendly  
Hydrocarbon Refrigerant



Energy Consumption



Temperature Uniformity

# Pharmacy Refrigerator

## Scope of Application

Used for storage of medicines, vaccines, reagents, biological products and other items that require a temperature between 2-8°C in hospitals, pharmacies, pharmaceutical factories, clinics and laboratories etc.

## Innovative Design

- High performance with low noise level
- Eco-friendly and energy saving
- Condensation free even at ambient 32°C & 80% RH
- Convenient monitoring and data export

# Pharmacy Refrigerator HYC-1031GD (115V)

## Product Features



Eco-friendly hydrocarbon refrigerant (R290) and CFC- free polyurethane insulation for reduced global warming potential



Hermetically sealed compressor, forced-air circulation with auto defrost to ensure high cooling performance, temperature uniformity  $\pm 1.5^{\circ}\text{C}$ ; anti-freezing thermostat is available to protect store items from freezing



Triple-paned tempered glass door with frame heater to reduce condensation even at  $32^{\circ}\text{C}$ , 80% RH ambient; self-closing door hinge; magnetic gaskets to ensure a positive seal



Energy efficient interior LED lighting, side-mounted



Optional USB module to easily record and export cabinet temperature and alarm data; optional RS485 port for easily external connection; optional printer to easily export cabinet temp data



Two 25mm probe access port on each side wall to accept user-provided monitoring equipment



Multiple alarm functions for safer monitoring, audible/visual alert with mute function; remote alarm contact is quipped as standard



Convenient security with a top-mounted unique-key lock



4 swivel casters with 2 leveling feet for easy movement



Microprocessor controller, digital display with  $0.1^{\circ}\text{C}$  resolution; easy to check the min/max temperature in the past 24 hours



Adjustable plastic-coated wire shelves for improved circulation and flexible storage

# Pharmacy Refrigerator HYC-1031GD (115V)

## Product Details



## Product Dimension

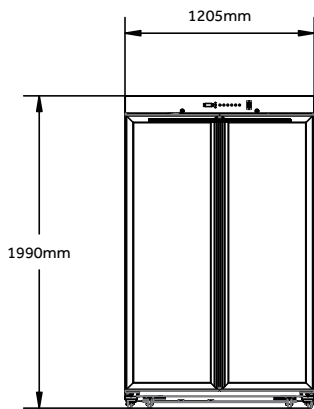

Front view

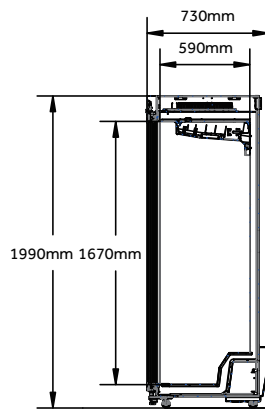

Side view

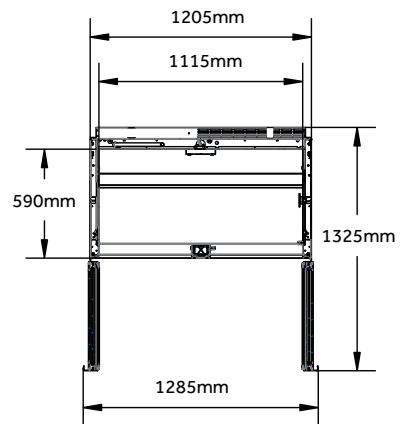

Top view



	Model	HYC-1031GD	
Technical Data	Cabinet Type	Upright, Glass Door	
	Climate Class	N, 16~32°C	
	Cooling Type	Forced Air Cooling	
	Defrost Mode	Auto	
	Refrigerant	R290	
	Sound Level (dB(A))	39	
Performance	Temperature Range (°C)	2~8	
Control	Controller	Microprocessor	
	Display	LED	
Electrical Data	Power Supply (V/Hz)	115/60	
	Electrical Current (A)	3.6	
Dimensions	Capacity (L/Cu.Ft)	1031 / 36.4	
	Net/Gross Weight (approx)	(kg)	255/265
		(lbs)	562/584
	Interior Dimensions (W*D*H)	(mm)	1115*590*1670
		(in)	43.9*23.2*65.7
	Exterior Dimensions (W*D*H)	(mm)	1205*800*1990
		(in)	47.4*31.5*78.3
	Packing Dimensions (W*D*H)	(mm)	1310*925*2150
		(in)	51.6*36.4*84.6
Container Load (20'/40'/40'H)		10/21/21	
Alarms	High/Low Temperature	Y	
	High Ambient Temperature	Y	
	Door Ajar	Y	
	Power Failure	Y	
	Low Battery	Y	
	Sensor Error	Y	
	Communication Failure	Y	
	Condenser Heat	Y	
	Remote Alarm	Y	
Accessories	Caster	4	
	Foot	2	
	Porthole	2	
	Shelves/Drawers	14/-	
	Printer	Optional	
	Chart Recorder	N/A	
	USB Interface	Optional	
	RS485	Optional	
	Electromagnetic Lock	N/A	
	Plastic Basket	Optional	
Others	Certification	UL, Energy Star	

\*Haier Biomedical reserves the right to change products and specifications without prior notice.